

ELEVATION

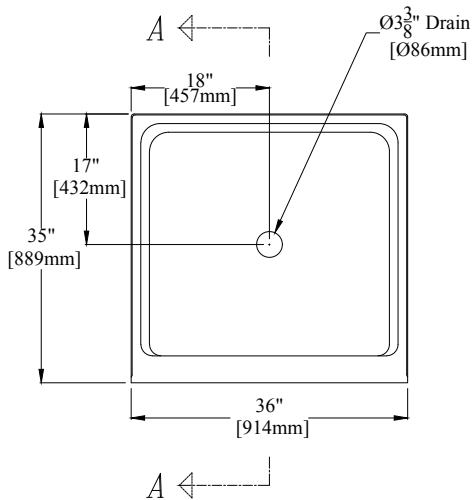

SECTION "A-A"



PLAN

*36" x 35" [914mm x 889mm] Shower Pan
w/ 6" [152mm] Threshold*

CENTER DRAIN

PRODUCT SPECIFICATIONS:

- * Product complies with NAHB, HUD UM-73A, and ANSI-Z124.1.2.
- * Product has a Class B fire rating as determined by ASTM E-84 test method.
- * Reinforced & slip resistant floor.
- * Integral 1" [25mm] nailing flange.
- * All dimensions +/- 1/2" [12.8mm]
- * Clarion Bathware reserves the right to change design and/or dimensions.

SP3635

36" x 35" [914mm x 889mm] Shower Pan w/ 6" [152mm] Threshold & Center Drain

Clarion
BATHWARE
44 Amsler Ave.
Shippenville, PA 16254

Phone: (814) 226-5374
Toll Free: (800) 576-9228
Fax: (814) 226-0730
www.clarionbathware.com

Signatures For Approval: _____ Date: _____
Customer: _____
Arch./Engr: _____
Quote #: _____
Job Name: _____

Dwg. #
SP3635-CUT

Dwg. By: NMH
DATE: 4/25/2017

***** IMPORTANT NOTICE *****

Clarion Bathware reserves the right to change the design and/or dimensions of its products at any time. This drawing may have been updated since this publication was issued. Before placing an order for any product, refer to our website at www.clarionbathware.com to obtain the most current drawings for any products that you wish to purchase. Compare the date of revision of the drawing that you have with the one on the drawing on our website. If you do not have internet access, please call your sales representative or Clarion Bathware's sales department at 1-800-576-9228.